

BURNER FIRE CONTROL

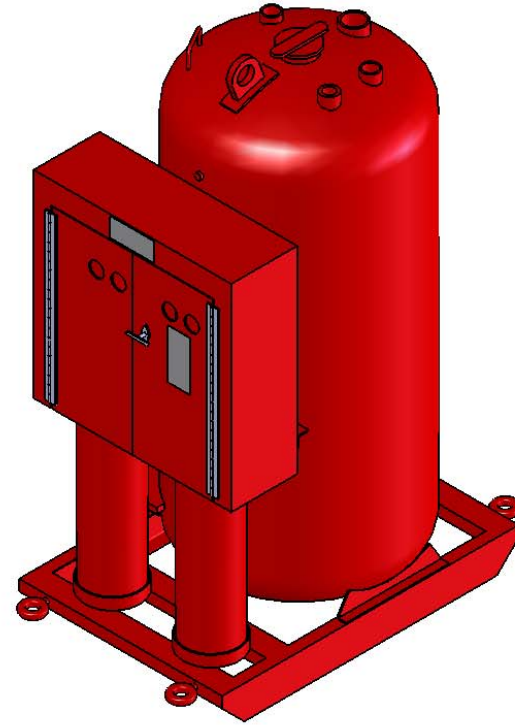

300 GALLON AFFF UNIT

1	250 PSI SAFETY POP-OFF VALVE
2	LIFTING EYELET
3	4" FILLER CAP
4	PIPE ELBOW
5	BACK CHECK VALVE
6	HOSE PURGE COLLAR
7	FLEX HOSE TO HOSE PURGE COLLAR
8	GAUGE INSPECTION PORT
9	REGULATED PRESSURE GAUGE (600 PSI)
10	HIGH PRESSURE GAUGE (3000 PSI)
11	STAINLESS STEEL DOOR HINGE
12	UNIT CABINET
13	SKID TOW EYE
14	UNIT SKID
15	PNEUMATIC VALVE ACTUATOR
16	NITROGEN CYLINDER REGULATOR
17	MANIFOLD
18	300 CU. FT. NITROGEN CYLINDER
19	NITROGEN CYLINDER MOUNTING BRACKET
20	NITROGEN CYLINDER VALVE

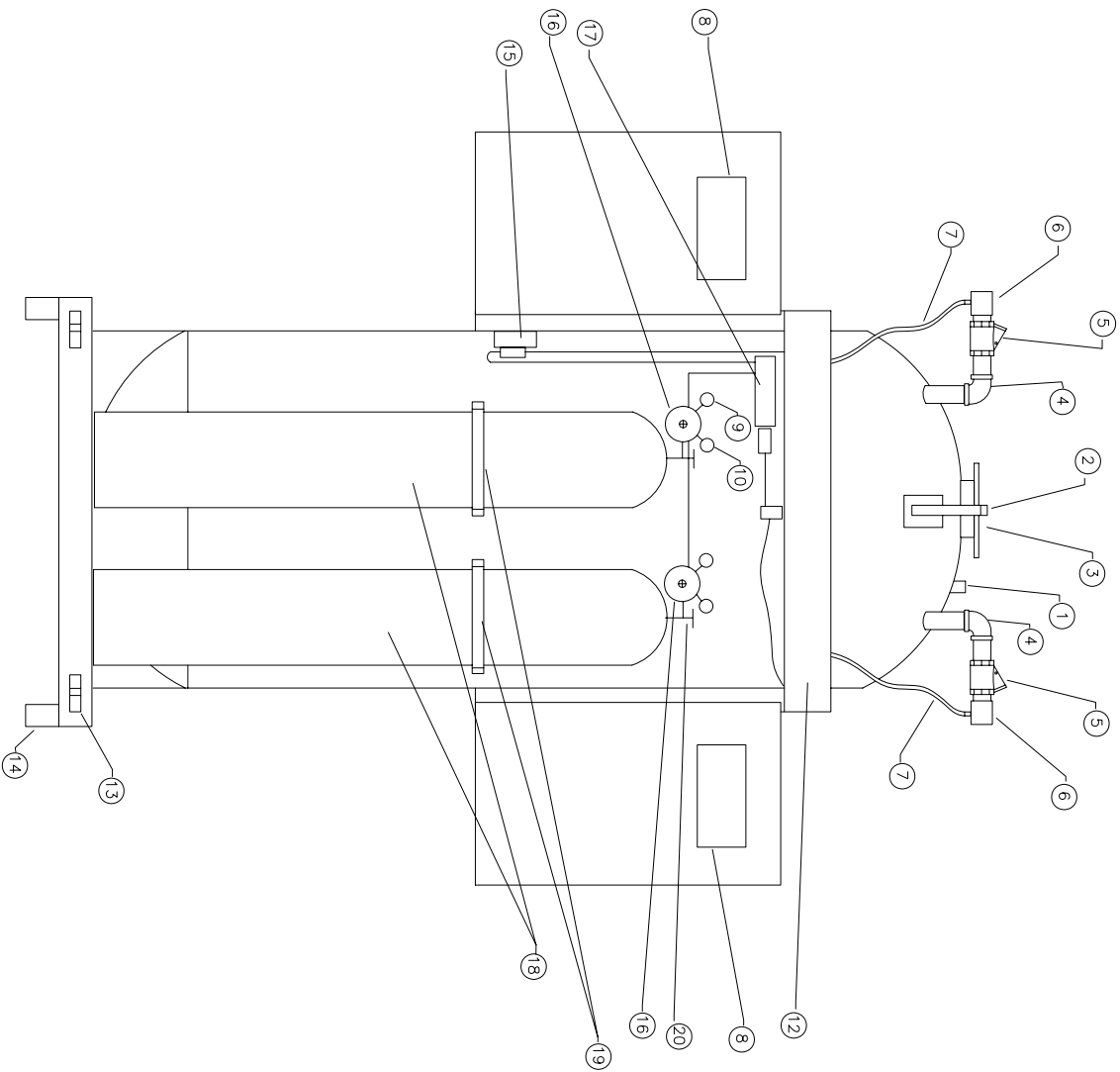

NOTES:
 DRY WEIGHT OF UNIT-----1,900 LBS.



We support and encourage NICET certification

THIS DRAWING IS CAD GENERATED AND THE PROPERTY OF BURNER FIRE CONTROL, INC.
 USE OR REPRODUCTION OF ANY PORTION MUST BE WITH THE CONSENT OF BURNER FIRE CONTROL, INC.



DRAWN BY: D. DELCAMPRE DATE: 6/1/07
 APPROVED BY: _____ DATE: _____

COMPANY: AMERICAN FIRE EQUIPMENT
 FACILITY: _____
 DRAWING: 300 GALLON AFFF UNIT
 DRAWING # 800-27

